

## DATASHEET

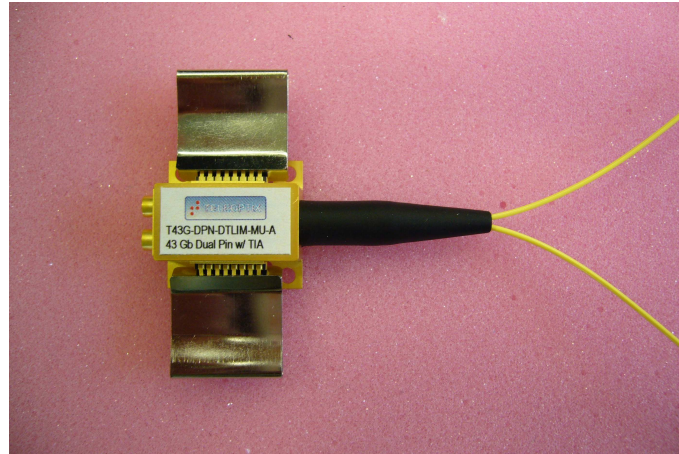

### Module information :

**Description:** The 43 Gb/s photo-receiver module integrates a dual UTC photodiode array with a differential trans-impedance amplifier suitable for 43Gb/s DPSK optical transmissions. Thanks to the optical characteristics of the UTC photodiodes associated with a high performances limiting amplifier exhibiting a typical differential output voltage swing of 700 mV<sub>pp</sub>, this dual-photodiode receiver is well adapted to OC-768/STM-256 optical transmissions. Combining output DC offsets with corresponding input threshold adjustments by an external loop allows to control the crossing-point of the differential output signal. The module is in a 16 pin package format with GPPO and LC/PC optical connectors.

### Main Features:

- Up to +3 dBm optical input power per photodiode
- 3dB sensitivity improvement
- Butterfly package with GPPO™ connectors
- Low polarisation dependent loss (typ. : 0.2 dB)
- Differential RF output, AC-coupled
- 700 mV differential output swing
- Operating case temperature: 0°...70°C
- Excellent OSNR performances: < 19 dB in 0.1nm at BER 10<sup>-9</sup>
- Stable OSNR performances with temperature (up to 70°C): < 0.5 dB

Opto and micro- chips are designed and fabricated by

### Applications :

- Advanced modulation formats at 43 Gb/s, DPSK or DQPSK, optical transmissions
- WDM optical transmissions

### Enclosed data :

1. Block Diagram
2. Absolute Maximum Ratings
3. Typical Operating Conditions
4. Main characteristics
5. Connector and Fibre Specification
6. Mechanical Dimensions
7. Pin Allocation
8. Ordering Information

## 1. Block Diagram

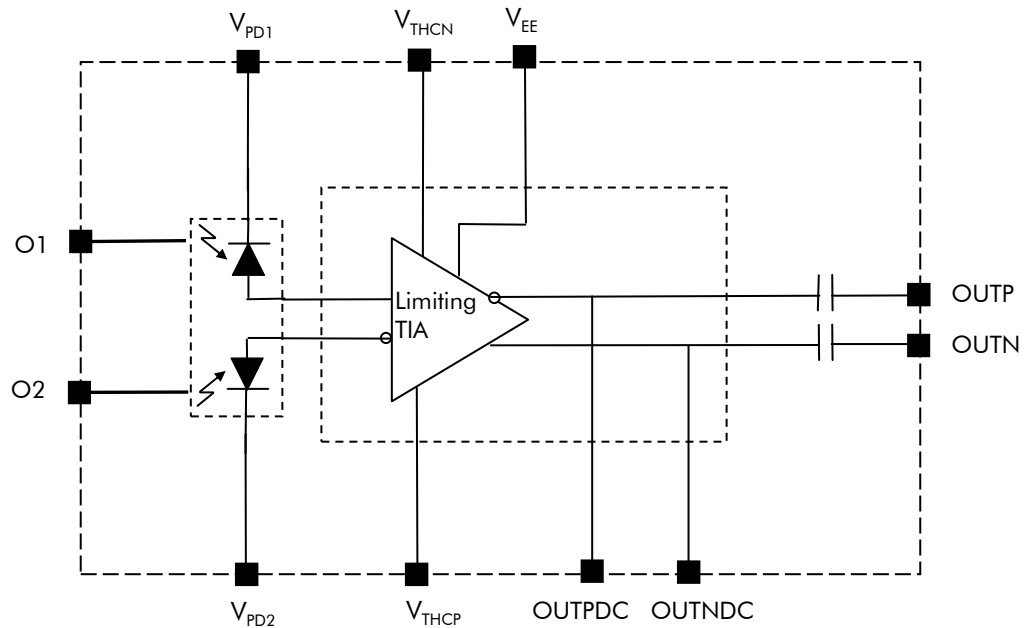

$V_{PD1,2}$  : Photodiodes power supply voltages

$V_{EE}$  : Amplifier power supply voltage

$V_{THCN}$ ,  $V_{THCP}$  : Threshold Controls (adjust these values in order to get OUTPDC and OUTNDC balanced)

OUTPDC, OUTNDC : DC output offsets

## 2. Absolute Maximum Ratings

Parameter	Symbol	Min	Max	Unit
PD bias voltage	$V_{PD1,2}$	-0.5	+ 3.5	V
Amplifier power supply voltage	$V_{EE}$	- 3.5	+0.5	V
Threshold Control Voltage	$V_{THCP}, V_{THCN}$	- 6.0	+6.0	V
Optical input power	$P_{optIN\ mean}$	-	+ 3	dBm
Operating temperature	$T_{OP}$	0	+ 70	°C
Storage temperature	$T_{ST}$	- 40	+ 80	°C

## 3. Typical Operating Conditions

Parameter	Symbol	Typ.	Unit
Amplifier power supply voltage	$V_{EE}$	- 3.3	V
Amplifier power supply current	$I_{EE}$	-130	mA
Threshold Control Voltage	$V_{THCP}, V_{THCN}$	$\pm 5.0$	V
Threshold Control Current	$I_{THCP}, I_{THCN}$	< 5.0	mA
Amplifier power dissipation	$P_{DC}$	< 500	mW
PD bias voltage	$V_{PD1}, V_{PD2}$	+2.3	V

#### 4. Main Characteristics

N°	Parameter	Symbol	Conditions	Min	Typ.	Max	Unit
1	Wavelength range	$\lambda$		1525		1620	nm
2	Optical Input Power <sup>(3)</sup>	$P_{optIN\_mean}$			-2		dBm
3	PD <sub>1,2</sub> responsivity	$R_{PD1,2}$	$V_{PD1} = + 2.3 V$	0.4	0.55	-	A/W
4	PD dark current	$I_{Dark}$	$V_{PD1,2} = + 2.3 V$	-	10	100	nA
5	PDL <sub>1,2</sub> polarisation dependent loss	PDL <sub>1,2</sub>	$V_{PD1} = + 2.3 V$	-	0.2	0.5	dB
6	3 dB bandwidth <sup>(1)</sup>	$f_{-3dB}$	$V_{PD1,2} = +2.3V$ $V_{EE} = -3.3 V$	30 (tbc)	35 (tbc)	-	GHz
7	Electrical return loss	S22	DC ~ 20 GHz 20 GHz ~ 45 GHz	-	-10 - 4	-	dB
8	Small signal differential conversion gain <sup>(2,5)</sup>	$G_{Conv\_diff}$	$V_{EE} = -3.3 V$	-	1500	-	V/W
9	Differential output eye amplitude <sup>(3)</sup>	$V_{out\_diff}$	$V_{EE} = -3.3 V$	-	700	-	mV <sub>pp</sub>
10	Optical path delay <sup>(4)</sup>	$O_{PD}$	-	-	0.5	1	ps
11	OSNR Performance <sup>(3)</sup>	OSNR	BW = 0.1nm BER = 10 <sup>-9</sup>		19		dB
12	OSNR vs Temp <sup>(3)</sup>	OSNR <sub>temp</sub>	from 32 °C Up to 70°C		0.5		dB
13	Power dissipation	$P_{DC}$	$V_{EE} = -3.3 V$	-	450	500	mW

Notes : (1) : Measurements performed in single-ended operation with 0 dBm optical input power.

(2) :  $G_{Conv\_diff} = Eye\_amp(differential) / P_{opt\_INpp}(differential)$ .

$P_{optIN\_mean}$  (injected on both photodiodes) = -10dBm.

Evaluated from NRZ eye diagram measurements at 43 Gbit/s.

(3) : Evaluated from measurements in 43 Gbit/s DPSK system.

(4) : Between the two input fibres.

(5) : Differential output voltage.



**7. Pin Allocation**

Pin	Name	Pin	Name
1	VPD1	16	VPD2
2	GND	15	GND
3	THCN	14	GND
4	THCP	13	VEE
5	GND	12	No internal connection
6	No internal connection	11	No internal connection
7	OUT P DC	10	No internal connection
8	OUT N DC	9	No internal connection

**8. Ordering Information:**

For orders or more information, please contact our sales office:

Mi.Tel-Teleoptix srl

Via Guido Rossa, 22

20040 Cornate D'Adda (MI)

ITALY

Tel.: +39 039 6101940

Fax.: +39 039 6101900

[www.teleoptix.com](http://www.teleoptix.com)

[info@teleoptix.com](mailto:info@teleoptix.com)